



MACHINE FEATURES

- Heavy-duty rugged construction designed for high durability and around-the-clock operation
- Compact, single frame design (wrapper with integrated tunnel)
- Laser cut and CNC machined components for maximum precision
- Powder coat finish that provides a durable scratch resistant surface and prevents corrosion
- Speeds up to 75 bundles per minute
- Wraps random sized stacks on demand
- Servo controlled continuous motion seal head provides smooth and quick transition of product through the wrapper at high speeds
- Servo drives provide excellent repeatability throughout the life of the machine
- Quick change plasma-coated seal bars for long life and easy maintenance
- Timing belt stabilized seal frame reduces maintenance and dirt accumulation
- Independent variable speed drives on the wrapper and tunnel
- Zero tension film feed prevents paper sheets or slippery magazines from shingling
- Side mounted film cradles for easy film loading

- Shrink tunnel with product cooling section at the tunnel exit speeds film curing
- Durable Intralox conveyor belts eliminate tracking problems
- Low film alert warns that a film changeover will soon be necessary
- Allen-Bradley® programmable logic controller with ARPAC standard operator interface
- Digital controls for fast and accurate setup
- NEMA 12 electrical cabinet and controls
- Central point lubrication allows for routine maintenance without stopping production

APPLICATIONS

- Magazines
- Periodicals
- Newspapers
- Books
- E-commerce applications
- Mailers
- Paper Products
- Tabloids
- Catalogs

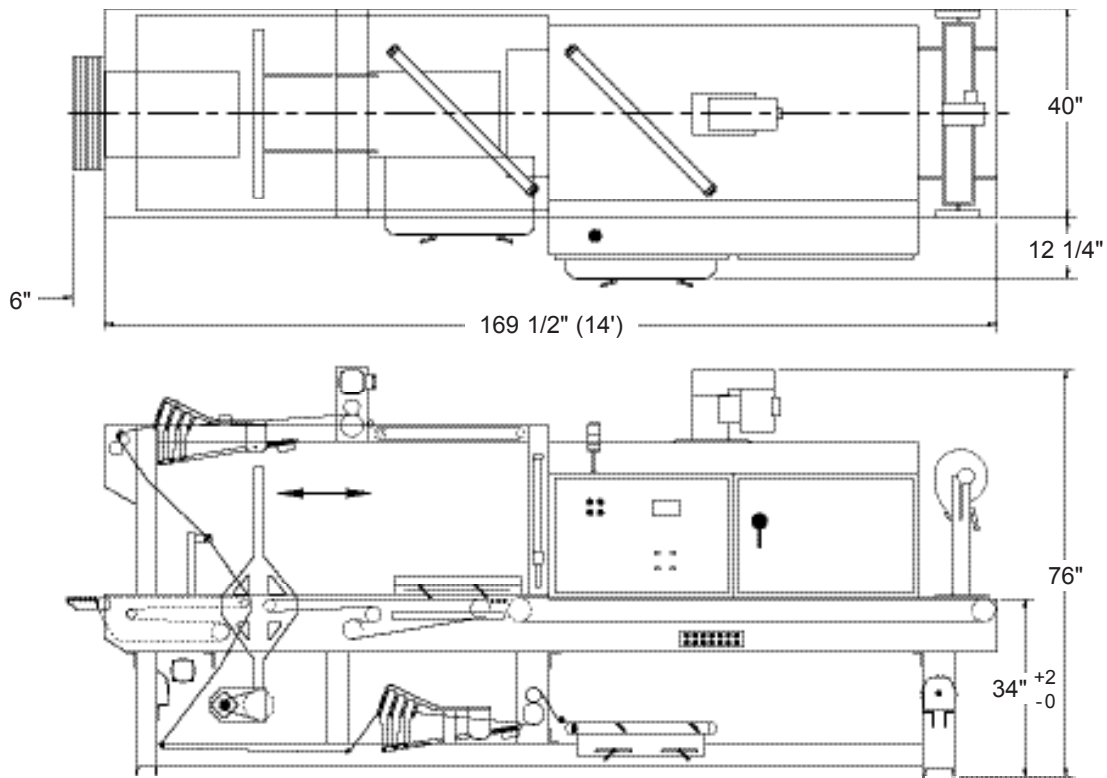

OPTIONS

- Split belt conveyor allows wrapping of thin and lightweight products. This is typically used for e-commerce applications where product is placed on a chipboard or corrugated pad prior to wrapping
- Collating systems for grouping stacks of products together before they proceed through the seal frame and into the shrink tunnel
- On certain high-gloss or stitched products, static charging may be necessary to hold the bundle together while shrink wrapping. Please consult ARPAC when this may be an issue
- Casters for machine portability
- Side smoothing rollers to smooth out odd shaped bull's eyes

SPECIFICATIONS

Speed

- Output speed: up to 75 packages per minute

Power Requirements

Electrical

- 480V, 3Ph, 60Hz, 50A, 40kW
- Note: other voltages available on request

Pneumatic

- 80 psi, 12 CFM

Product Range

- Width: 5" to 12"
- Length: 7" to 18"
- Height: 3/16" to 10"

Film

- Max. film width: 27" single-wound
- Clear or randomly printed
- Film roll diameter: up to 14" with a 3" core
- Film gauge: up to 6 mil. maximum
- Film type: low density polyethylene (L.D.P.E.)



User-Friendly Operator Controls



Servo-Driven Sealing System for Lower Operating Costs and Better Efficiency



Automatic Product Height Detection for Random Sizes