

SPINNER

Manually Operated Stretch Wrapper

ARPAC®

A DURAVANT COMPANY



max load weight: 4,000 lbs.
max load size: 50" x 50"

FEATURES & BENEFITS

Machine Features

- Forklift portable (either end, hp only)
- Turntable system
- Welded heavy-duty reinforced structural steel construction for around-the-clock operation
- Powder coat finish that provides a durable scratch resistant surface and prevents corrosion
- 4 point caster support for HP turntable
- 6 point - Delrin caster support for LP turntable
- Turntable direct drive: 1/2 HP, DC motor with ANSI 50 chain
- Variable turntable speed (0-12 RPM)
- UL approved components

SPECIFICATIONS

Power Requirements

- Electrical: 120V, 1Ph, 60Hz, 10A
- Foot pedal control

Film Delivery System

- Hand wrapper

Approximate Shipping Weight

- HP: 560 lbs.
- LP: 650 lbs.

OPTIONS

- Turntable System
- 50" x 90" Turntable
- 60" sq. Turntable (hp)
- Wrap-N-Weigh scale
- Access ramps (LP only)
- Standard ramp
- Extended access ramp (powered pallet jack)
- Wrap-N-Weigh access ramp
- Wrap-N-Weigh extended ramp (powered pallet jack)

Low and High Profile Tables
Note: Final Layout May Vary

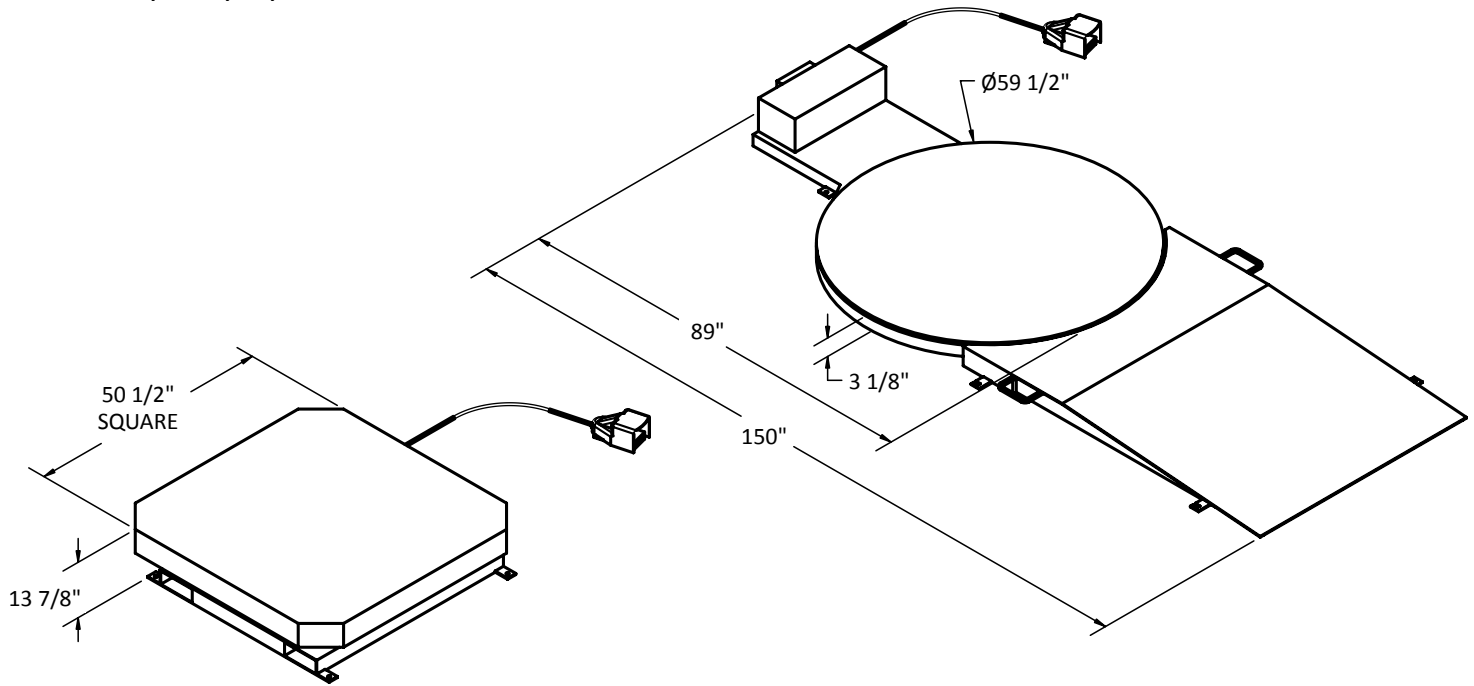

**Complete Aftermarket
Service & Support
for Your Packaging
Equipment**

SUPPORTPRO™

A DURAVANT SERVICE

Call **844.777.8776** for your regional tech

24/7 Help Available



THE DURAVANT FAMILY OF COMPANIES

ARPAC | FISCHBEIN INTERNATIONAL | FMH CONVEYORS | HAMER-FISCHBEIN | KEY TECHNOLOGY | MARLEN INTERNATIONAL | MESPACK | OHLSON | QC INDUSTRIES

www.duravant.com